

# 18" Solid Wall Steel Corrugated Container.

Standard Drop Gate not available for these sizes.  
 Standard Hopper Front not available for these sizes.  
 \*\*51023, 51020 & 51012 Stacked 3 high for shipping.

Model No. Unpainted	Tare Wt.	*Nominal I.D. L x W x H	Overall Dimensions L x W x H
**51023	91	24" x 24" x 18"	25.5" x 25.5" x 23.5"
**51020	100	24" x 30" x 18"	25.5" x 31.5" x 23.5"
**51012	110	30" x 30" x 18"	31.5" x 31.5" x 23.5"
51013	120	30" x 35" x 18"	31.5" x 36.5" x 23.5"
51014	136	30" x 42" x 18"	31.5" x 43.5" x 23.5"
51000	132	35" x 35" x 18"	36.5" x 36.5" x 23.5"
51001	152	35" x 42" x 18"	36.5" x 42.5" x 23.5"
51002	159	35" x 48" x 18"	36.5" x 49.5" x 23.5"
51003	163	42" x 42" x 18"	43.5" x 43.5" x 23.5"
51004	184	42" x 48" x 18"	43.5" x 49.5" x 23.5"
51005	197	48" x 48" x 18"	49.5" x 49.5" x 23.5"

\*(L xW) are measured from outside wall-to-wall and (H) is the outside height of the wall. To calculate clear/usable ID -1.63" from (LxW) Nominal ID & -1.25" from (H) Nominal ID.



\*\*Ship Stack Height 90"

**CAPACITY:** 4,000 lbs. (UDL) uniformly distributed load.  
**STATIC STACKING:** 5 High maximum, empty and/or full.  
**SHIP STACKING:** 4 High maximum in High Cube Dry Van. FOB WI 53177, NMFC 9950-01; Class 200.  
**HANDLING:** 4" Four-way under clearance on all sides.  
**MATERIAL:** Plain carbon steel construction throughout.  
**FINISH 1:** Unpainted, bare/raw steel.  
**FINISH 2:** Industrial enamel applied direct to metal inside & out but not including underside.  
**COLORS:** Blue, Green, Grey, Teal, or Black.  
**OTHER:** Containers will not hold liquids or parts smaller than a 5/8" ball bearing and are not FDA approved.

Custom Sizes Available Upon Request

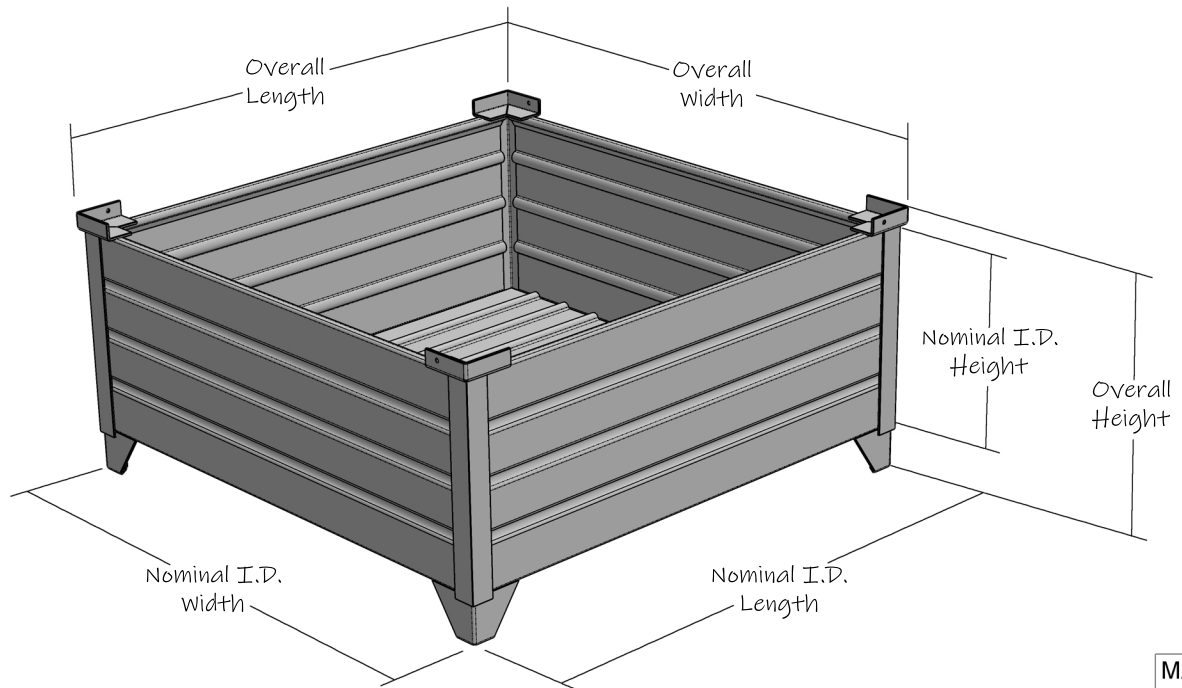

1729 NE Frontage Road  
 Sturtevant, WI 53177  
 Ph: 262-886-6931  
 Sales@TopperIndustrial.com

MADE IN THE USA

Since 1997

TOPPER, INC. © COPYRIGHT 2022